

Technical Specification

Optional Accessories

- > Low reservoir alarm.
- > External salt fog collection vessels.
- > Salt fog condenser venting system.
- > Variable humidity – 15%RH to 98%RH with controlled temperature.
- > Compressor – available for continuous use or stand-by function: high specification, oil free.
- > Compressor switch – for automatic switch-over to stand-by or regular air supply.
- > De-ioniser & water filters – recommended for areas with hard water or high total dissolved solids (50mg/litre TDS)
- > Entry ports – for cable access to monitoring equipment or power induction.
- > Special racking – to support components/samples in test areas as required.



| Cabinet Type | | Cyclic Corrosion Test Cabinets CCT | | | |
|----------------------------------|----------------|---|-------------------------|--|----------------------------|
| Models | | SF/200/CCT 200 litre | SF/450/CCT 450 litre | SF/1000/CCT 1000 litre | SF/2000/CCT 2000 litre |
| Style | | Floor Mounted | | | |
| External Dimensions | L | 1030mm | 1370mm | 1960mm | 2400mm |
| | W | 700mm | 930mm | 1335mm | 1200mm |
| | H | 1050mm | 1130mm | 1410mm | 1645mm |
| Internal Dimensions | I | 610mm | 825mm | 1465mm | 2000mm |
| | W | 510mm | 635mm | 1040mm | 1000mm |
| | H ¹ | 455mm | 620mm | 720mm | 850mm |
| | H ² | 660mm | 875mm | 1065mm | 1175mm |
| Panel Capacity | | 80 | 132 | 344 | 516 |
| Power Supply Amp | | 16 | 16 | 32 | 3 Phase 380 V 50/60Hz |
| Compressed Air | | TYPE: Clean, dry, oil free PRESSURE: 30 to 60 psi (2 to 4 BAR) | | FLOW: 3.5cfm at 15 psi CONNECTION: 10mm ID plastic tape | 90 to 120 psi (6 to 8 BAR) |
| Services | | Power supply: 230 V 50/60Hz single phase other voltages available on request. | | | |
| Water | | TYPE: De-ionised or mains water below 50mg/litre TDS PRESSURE: 30 to 60psi (2 to 4 BAR) CONNECTION: 10mm ID plastic pipe | | | |
| Drain | | 36mm outside diameter plastic pipe to liquid waste with air breather / vent pipe connected | | | |
| Salt Solution Reservoir With Lid | | Supplied on castors with internal solution filter - 500mm x 620mm x 540mm (L x W x H) | | | |

CCT Cyclic Corrosion Test Cabinets

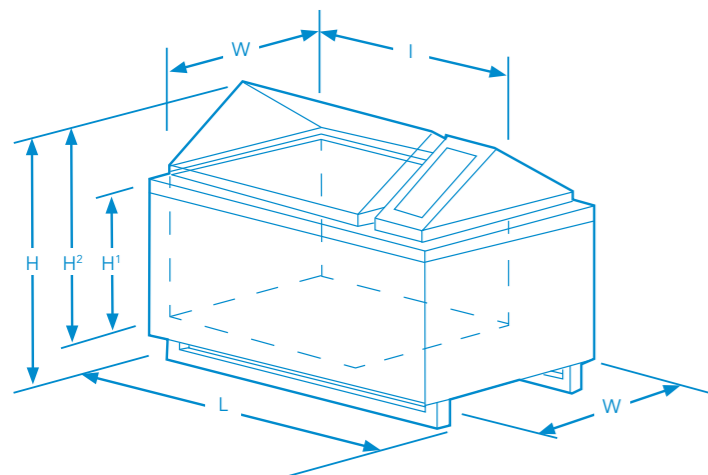

All cabinets are C.E marked and have calibration traceable to UKAS. Certificates of Conformity are supplied on request.
ISO 9001 Registered Company BSEN ISO 9001:2000.

Due to continuous development we reserve the right to introduce improvements and /or modify specifications without prior notice.

Designed and printed in England Ref: 11-05-CCT



Paytoe Lane, Leintwardine,
Craven Arms,
Shropshire,
SY7 0NB, UK

T: +44 (0) 1547 540654
F: +44 (0) 1547 540412
W: www.cw-spec.com
E: sales.service@cw-spec.com



CERT No. 3102

CCT Cyclic Corrosion Test Cabinets



Cyclic Corrosion Cabinets

Pioneering designs have made C & W the UK leader in the manufacture of accelerated corrosion and environmental test cabinets.

The C&W CCT range maintains this tradition, being designed to deliver the precise environmental test conditions demanded by modern industry and to do so time after time. Their reliability, ease of operation and robust construction has led to their use worldwide in all major sectors of automotive manufacture, as well as the paint, plastics, packaging, electronics, aerospace, military and offshore industries.



Model SF/450/CCT

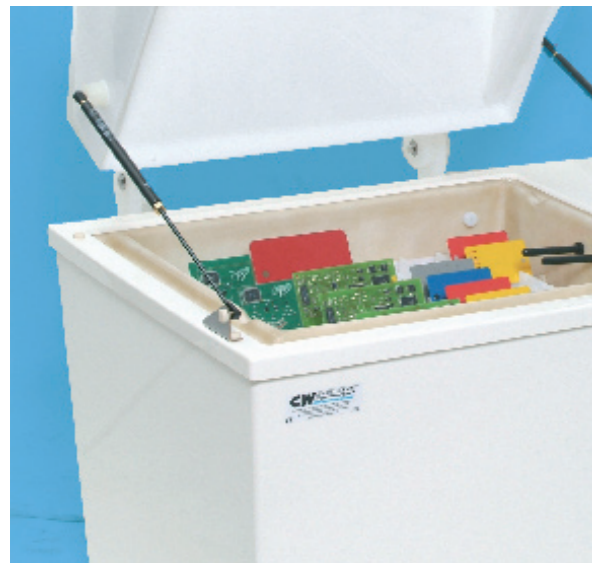

Operating Modes

The C&W CCT cabinet provides a full range of environmental test conditions including:

- > Conventional salt spray/ salt fog.
- > High humidity, 98% RH, at constant or cyclic temperatures.
- > Dry heat – ambient to 70°C.
- > Forced air drying.
- > Dwell and ramp functions.
- > Air purge cycles .
- > Ambient to 55°C +/- 1°C.

With its user-friendly programme logic controller, any one or any combination of these conditions can be selected, programmed in any sequence and for any pre-set time. CCT cabinets can also be used in single mode as the following:-

- > Cyclic Prohesion® Cabinet
- > CASS Cabinet
- > Conventional Salt Spray/ Salt Fog Cabinet
- > Humidity Cabinet

Design Benefits

CCT cabinets, with their clean, functional design are manufactured from high quality materials selected specifically for this application.

- > Specially formulated for retardant glass reinforced polyester (GRP) with high chemical and temperature tolerance.
- > Corrosion resistant construction throughout .
- > Wet or dry seal option.
- > Apex lids are available in a range of composite materials depending on test requirements, and supported by gas springs.
- > Ergonomically designed control panel.
- > Transportation in areas of restricted access is made easier due to the compact design aided by removable lids and base frames.

Precise Control

C&W cabinets are designed for ease of operation. All units incorporate a microprocessor controller with the capacity to hold up to 7 programmes with unlimited event entries. Rapid programme selection and the facility to create new programmes to meet specific needs, puts the operator in total control.



- > The ability to monitor cycles, events and functions is made possible by the comprehensive package of control and display features
- > Full visual display of all events, cycles and test conditions
- > Programme run cycle counter with 'End of Test' facility
- > Accurate salt solution flow control via a variable speed, heavy duty peristaltic pump and flow meter. This ensures precise collection rates and eliminates atomizer blockage
- > Air regulator and gauge to control and monitor the air pressure required for precise salt spray rates

Optimum Operation

Effective corrosion testing requires rapid transition between test regimes with minimum fluctuation. In C&W's CCT cabinets these criteria are assured by:

- > Sophisticated atomiser ensuring even distribution of salt spray and precise collection rates throughout the chamber.
- > Automatic self filling humidifier system for compressed air saturation. Overheating and low water protection. Fully adjustable water temperature control with digital display.
- > Dry/moist air facility included.
- > Air purge to remove corrosion air borne salt fog prior to sample inspection.
- > Mobile external salt solution reservoir with integral filter system. 114 litre capacity giving approximately 10 days continuous operation. Optional low level alarm system available.
- > Easy access for filling and sterilisation to prevent excessive growth of algae.
- > Internal humidification system for high humidity generation, 98% RH, with automatic level control.



Standards and Accreditation

C&W CCT cabinets conform to all leading corporate, national and international standards including:
ISO 7253, Toyota TSH 1555G, Ford EU B 153-2, BS 3900 F12, VDA 624-415, VW-1210-C, Renault, JIS-K 5622-7, SWAAT + Mastmaasis
Honda 5100Z, ASTM B117, GM 9540 P, DIN 50.021, Nissan M0007, CCT I, II & IV, Unichem 692 & 741

Quality Assured

All C & W Cabinets are manufactured to BSEN ISO 9001 :2000. Subject to agreed maintenance procedures a two year warranty is available – generally UK only. The standard warranty is one year.

